



WRAPMAN STH model

 Macchina con carrello frizionato e con regolazione manuale della tensione del film. La macchina lavora con qualsiasi tipo di film estensibile.

Machine with fricioned roller carriage and manual tension adjusting of the film. The machine works with any type of stretch film.

Maschine mit Wagen mit Kupplung und manueller Einstellung der Folienspannung. Die Maschine arbeitet mit jeder Art von Stretchfolie.

WRAPMAN model

 Macchina con prestiro motorizzato 100% (option 200%). Dimezza i costi d'imballo ed è ideale per prodotti leggeri ed instabili.

Machine with motorized Power pre-stretch of 100% (option 200%). Half the costs of packaging and its ideal for light and unstable products.

Maschine mit motorisierter Vordehnung 100% (Option 200%). Halbiert die Kosten für die Verpackung und ist ideal für leichte und unstabile Produkte.

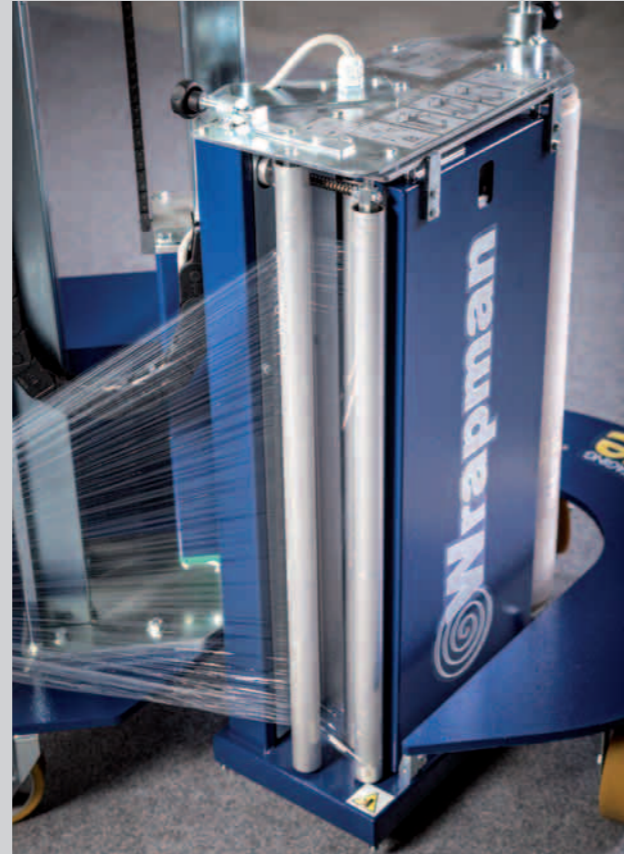

60 cm

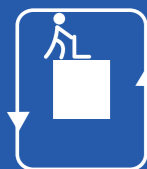

L'unico sistema per imballare con soli 60 cm di distanza dal pallet.

The only system for wrapping with 60 cm around the pallet.

Einziges System, das die Verpackung mit einem Abstand von nur 60 cm von der Palette ermöglicht.



Nessuno sforzo per l'operatore: il tensionamento del film è totalmente a carico di Wrapman.

No effort for the operator: the stretching of the film is totally to load of Wrapman.

Keinerlei Aufwand für den Benutzer: Die Spannung der Folie wird allein vom Wrapman ausgeführt.



Facile, robusto e leggero, nessuno sforzo per l'operatore

Easy, strong and light no operator effort

Intuitiv, robust und leicht, ohne Aufwand für den Benutzer.



www.edtarimini.com

L'unica soluzione per imballare carichi di qualsiasi peso, sagoma, dimensione e forma. L'unica soluzione che garantisce massima protezione al carico a costi d'imballo dimezzati.

The unique solution of wrapping loads of any weight, profile, dimension and shape. The unique solution that guarantees maximum protection to the load with halved packaging costs.

Einzige Lösung, die die Verpackung von Produkten mit jedem Gewicht, jeder Form und Größe ermöglicht. Einzige Lösung, die zu halbierten Verpackungskosten maximalen Schutz der Produkte garantiert.

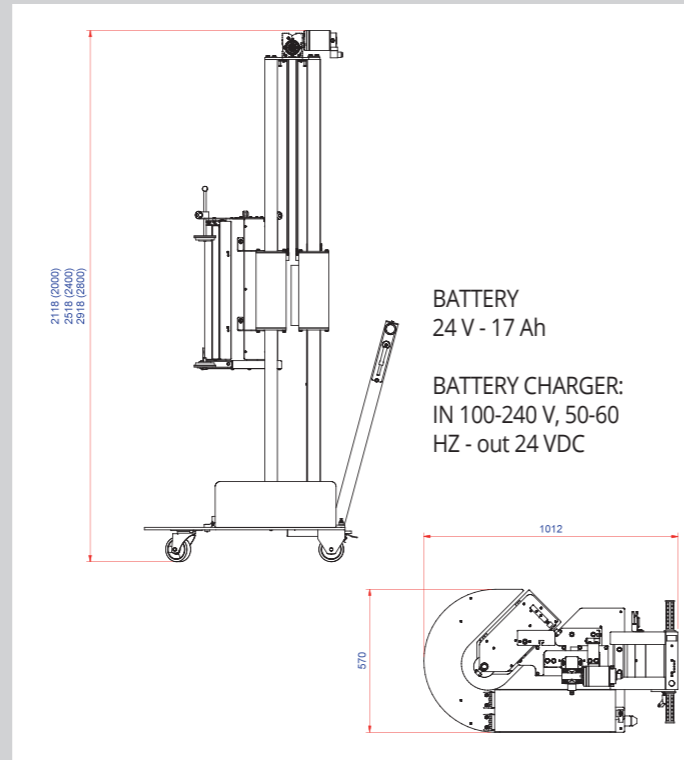

available models	max useful pallet heigh	spool carriage type	max diameter film coil	core types of film coil	H (mm)	L (mm)	W (mm)	weight
WRAPMAN STH	2.0	frictioned roller	180 m	50-76	2119	1115	570	114 kg.
WRAPMAN STH	2.4	frictioned roller	180 m	50-76	2518	1012	570	116 kg.
WRAPMAN	2.0	power pre-stretch	145 m	50-76	2119	1115	570	121 kg.
WRAPMAN	2.4	power pre-stretch	145 m	50-76	2518	1012	570	123 kg.
WRAPMAN	2.8	power pre-stretch	145 m	50-76	2918	1012	570	137 kg.

